

SC15GHH

Heat Pump Compressor

R134a

220-240V 50Hz

General

Code number	104G8571
Approvals	EN 60335-2-34
Compressors on pallet	80

Application

Application	HBP		
Frequency	Hz	50	60
Evaporating temperature	°C	-15 to 15	-
Voltage range	V	198 - 254	-
Max. condensing temperature continuous (short)	°C	70 (70)	-
Max. winding temperature continuous (short)	°C	125 (135)	-

Cooling requirements

Frequency	Hz	50			60		
Application		LBP	MBP	HBP	LBP	MBP	HBP
32°C		-	-	O	-	-	-
38°C		-	-	O	-	-	-
43°C		-	-	O	-	-	-
Remarks on application:							

Motor

Motor type	CSR		
LRA (rated after 4 sec. UL984), HST LST	A	14.8	-
Cut in Current, HST LST	A	14.8	-
Resistance, main start winding (25°C)	Ω	5.0	13.7

Design

Displacement	cm ³	15.28
Oil quantity (type)	cm ³	450 (polyolester)
Maximum refrigerant charge	g	1300
Free gas volume in compressor	cm ³	1540
Weight without electrical equipment	kg	13.4

Dimensions

Height	mm	A	209
		B	203
		B1	183
		B2	100
Suction connector	location/I.D. mm angle	C	10.2 37°
	material comment	Cu-plated steel Al cap	
Process connector	location/I.D. mm angle	D	6.2 37°
	material comment	Cu-plated steel Al cap	
Discharge connector	location/I.D. mm angle	E	8.2 37°
	material comment	Cu-plated steel Al cap	
Oil cooler connector	location/I.D. mm angle	F	8.2 -
	material comment	Cu-plated steel Al cap	
Connector tolerance	I.D. mm	±0.09	
Remarks:			

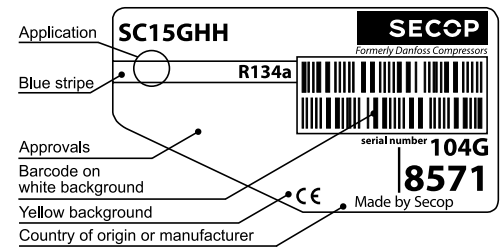

- S = Static cooling normally sufficient
- O = Oil cooling
- F₁ = Fan cooling 1.5 m/s (compressor compartment temperature equal to ambient temperature)
- F₂ = Fan cooling 3.0 m/s necessary
- SG = Suction gas cooling normally sufficient
- = not applicable in this area

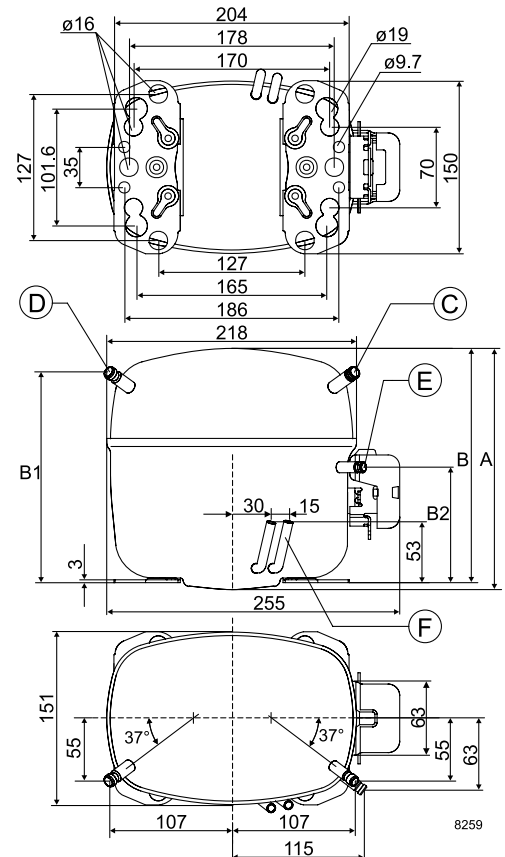

EN 12900 Household (CECOMAF) 220V, 50Hz, fan cooling F₁

Evap. temp. in °C	-45	-40	-35	-30	-25	-23.3	-20	-15	-10	-6.7	-5	0	5	7.2	10	15	20
Capacity in W								435	570	679	726	911	1135	1262	1405	1731	
Power cons. in W								345	377	403	417	461	505	523	543	573	
Current cons. in A								1.71	1.84	1.95	2.01	2.20	2.39	2.47	2.56	2.70	
COP in W/W								1.26	1.51	1.69	1.74	1.98	2.25	2.41	2.59	3.02	

ASHRAE HBP 220V, 50Hz, fan cooling F₁

Evap. temp. in °C	-45	-40	-35	-30	-25	-23.3	-20	-15	-10	-6.7	-5	0	5	7.2	10	15	20
Capacity in W								536	703	836	896	1127	1405	1560	1742	2150	
Power cons. in W								345	377	403	417	461	505	523	543	573	
Current cons. in A								1.71	1.84	1.95	2.01	2.20	2.39	2.47	2.56	2.70	
COP in W/W								1.55	1.87	2.07	2.15	2.44	2.78	2.99	3.21	3.75	

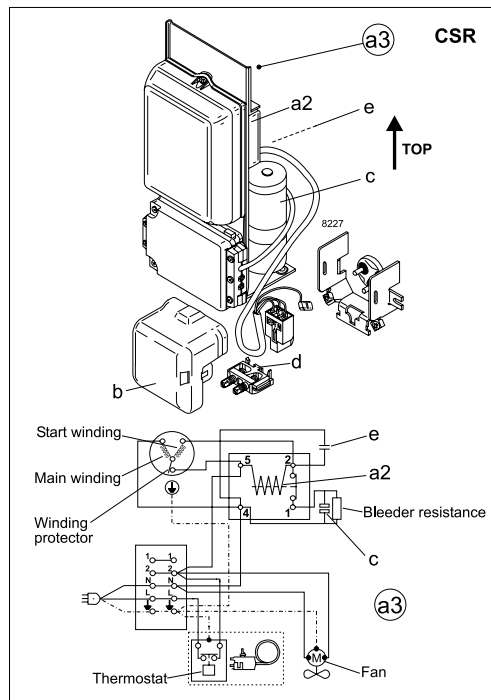

Accessories for	SC15GHH	Figure	Code number
Starting device	470 mm cable length	a3	117-7012
Cover		b	103N2009
Starting relay		a2	Components of starting device
Start. capacitor		c	
Run capacitor		e	
Cord relief		d	103N1004

Test conditions	EN 12900/CECOMAF	ASHRAE HBP
Condensing temperature	55°C	55°C
Ambient temperature	32°C	35°C
Suction gas temperature	32°C	35°C
Liquid temperature	55°C	32°C

Mounting accessories		Code number
Bolt joint for one comp.	Ø: 16 mm	118-1917
Bolt joint in quantities	Ø: 16 mm	118-1918
Snap-on in quantities	Ø: 16 mm	118-1919

Danfoss can accept no responsibility for possible errors in catalogues, brochures and other printed material. Danfoss reserves the right to alter its products without notice. This also applies to products already on order provided that such alterations can be made without subsequential changes being necessary in specifications already agreed. All trademarks in this material are property of the respective companies. Danfoss and the Danfoss logotype are trademarks of Danfoss A/S. All rights reserved.